

◆ ◆ ◆ ◆ ◆  
◆ ◆ ◆ ◆ ◆

# Instruction manual

◆ ◆ ◆ ◆ ◆  
◆ ◆ ◆ ◆ ◆

## General instructions digital Mass Flow instrument CORI-FLOW

Doc. no.: 9.17.031F Date: 28-07-2011

◆ ◆ ◆ ◆ ◆  
◆ ◆ ◆ ◆ ◆  
◆ ◆ ◆ ◆ ◆  
◆ ◆ ◆ ◆ ◆

### ATTENTION

Please read this instruction manual carefully before installing and operating the instrument.  
Not following the guidelines could result in personal injury and/or damage to the equipment.

◆ ◆ ◆ ◆ ◆  
◆ ◆ ◆ ◆ ◆

## SCOPE OF THIS MANUAL

This manual covers the general part of digital CORI-FLOW mass flow instruments for gases and liquids. It treats the general instructions needed for the instruments. More information can be found in other documents.

Multibus instruments have modular instruction manuals consisting of:

- **General instructions CORI-FLOW (document nr. 9.17.031)**
- Operation instructions digital instruments (document nr. 9.17.023)
- Fieldbus/interface description:
  - FLOW-BUS Interface (document nr. 9.17.024)
  - PROFIBUS-DP Interface (document nr. 9.17.025)
  - DeviceNet Interface (document nr. 9.17.026)
  - RS232 Interface with FLOW-BUS protocol (document nr. 9.17.027)
  - Modbus interface (9.17.035) special request

Even though care has been taken in the preparation and publication of the contents of this manual, we do not assume legal or other liability for any inaccuracy, mistake, mis-statement or any other error of whatsoever nature contained herein. The material in this manual is for information purposes only, and is subject to change without notice.

Bronkhorst Cori-Tech B.V.  
July 2011

## **Warranty**

The products of Bronkhorst Cori-Tech B.V. are warranted against defects in material and workmanship for a period of three years from the date of shipment, provided they are used in accordance with the ordering specifications and the instructions in this manual and that they are not subjected to abuse, physical damage or contamination. Products that do not operated properly during this period may be repaired or replaced at no charge. Repairs are normally warranted for one year or the balance of the original warranty, whichever is the longer.

See also paragraph 9 of the Conditions of Sales.

The warranty includes all initial and latent defects, random failures, and indeterminable internal causes.

It excludes failures and damage caused by the customer, such as contamination, improper electrical hook-up, dropping etc.

Re-conditioning of products primarily returned for warranty service that is partly or wholly judged non-warranty may be charged for.

Bronkhorst Cori-Tech B.V. prepays outgoing freight charges when any part of the service is performed under warranty, unless otherwise agreed upon beforehand. However, if the product has been returned collect to Bronkhorst Cori-Tech B.V., these costs are added to the repair invoice. Import and/or export charges, foreign shipping methods/carriers are paid for by the customer.

## **Short-Form Operation Instruction**

Before installing your Mass Flow Meter/Controller it is important to read the attached label and check:

- Flow/pressure rate
- Fluid to be measured
- Up- and downstream pressures
- Input/output signal

Check the red-coloured sticker and make sure the test-pressure is in agreement with normal safety factors for your application.

Check if the piping system is clean. For absolute cleanliness always install filters to assure a clean, moisture- and oil-free gas stream.

Install the CORI-FLOW Meter/Controller in the line and tighten the fittings according to the instructions of the supplier of the fittings. Choose the mounting position according to the directions given in this manual.

Check the system for leaks before applying fluid pressure.

Electrical connections must be made with a standard cable or according to the hook-up diagram in the back of this manual.

### **Short form start-up**

Install instrument in your process.  
Provide instrument with correct pressure(s).

### **Analog operation**

Connect the instrument to the power supply/readout unit with the 9-pin cable at the circular connector.

### **BUS/digital operation**

For this procedure: see description for specific fieldbus.

Let the instrument warm-up for 30 minutes for best accuracy.

Zero the instrument.

Send a setpoint to the instrument and check the measured value.

Your Mass Flow Meter/Controller is now ready for operation.

## TABLE OF CONTENTS

1	INTRODUCTION .....	7
1.1	General description.....	7
1.1.1	Gas / Liquid flow .....	7
1.1.2	Housing .....	7
1.1.3	Valves.....	8
1.2	Sensor principles .....	9
1.2.1	Cori-Flow sensor .....	9
1.3	Valve principles.....	9
1.3.1	Solenoid valve .....	9
1.3.2	Vary-P valve .....	10
1.3.3	Pilot operated valve .....	10
1.3.4	Bellow valve.....	10
1.4	Software for physical properties of gases and liquids.....	10
2	INSTALLATION .....	11
2.1	Receipt of equipment.....	11
2.2	Return shipment .....	11
2.3	Service.....	11
2.4	Mounting .....	12
2.5	Notes for temperature changes .....	14
2.6	Fluid/gas connections .....	15
2.7	Piping.....	15
2.8	Electrical connections .....	15
2.9	Pressure testing.....	15
2.10	Supply pressure.....	15
2.11	System purging.....	15
2.12	Seals.....	15
2.13	Equipment storage.....	16
2.14	Electromagnetic compatibility .....	16
	Conditions for compliance with EMC requirements.....	16
2.15	Electro static discharge.....	17
3	OPERATION.....	18
3.1	General.....	18
3.2	Power and warm-up.....	18
3.3	Zeroing.....	19
3.3.1	Zeroing with the Micro-switch .....	19
3.3.2	Zeroing through the digital communication .....	19
3.4	Start-up .....	20
3.5	Operating conditions.....	20
3.6	Instrument performance .....	20
3.6.1	Meters.....	20
3.6.2	Controllers .....	20
3.7	Manual operation .....	20
3.8	Analog operation.....	20
3.9	BUS / digital operation .....	22
4	MAINTENANCE .....	23
4.1	General.....	23
4.2	Cori-Flow sensor.....	23
4.3	Controllers .....	23
4.4	Control valves.....	23
4.4.1	Solenoid valves .....	23
4.4.2	Vary-P valve .....	23
4.4.3	Pilot operated valve .....	24
4.4.4	Bellows valve.....	24
4.5	K <sub>v</sub> -value calculation .....	24
4.5.1	For gases .....	24
4.5.2	For Liquids.....	25
4.6	Calibration procedure .....	25
5	DIGITAL INSTRUMENT .....	26
6	INTERFACE DESCRIPTION.....	26
7	TROUBLESHOOTING.....	27
7.1	General.....	27
7.2	Troubleshooting summary general .....	27
8	SPECIAL APPLICATIONS.....	28

## Appendices

- 1 Enclosures (if applicable)
- 2 Hook-up diagram
- 3 Calibration certificate

# 1 INTRODUCTION

## 1.1 General description

### 1.1.1 Gas / Liquid flow

The Bronkhorst Cori-Tech B.V. series CORI-FLOW mass-flow meter/controller for gases and liquids is a accurate device for measuring gas and liquid flows up to 100 bar depending on body rating, virtually independent of pressure and temperature changes. The CORI-FLOW is a real mass-flow meter/controller it measures the flow in mass, it does not matter what the properties of the gases or liquids are. The system can be completed with a control valve and flexible readout unit to measure and control gas and liquid flows. It ranges from 20 g/h up to 600 kg/h at a  $\Delta P$  of 1 bar, however this can be higher if a greater  $\Delta P$  is allowed, depending on the specific type of instrument.

### 1.1.2 Housing

Each instrument housing style incorporates several provisions to comply with EMC requirements.

#### Meter housing

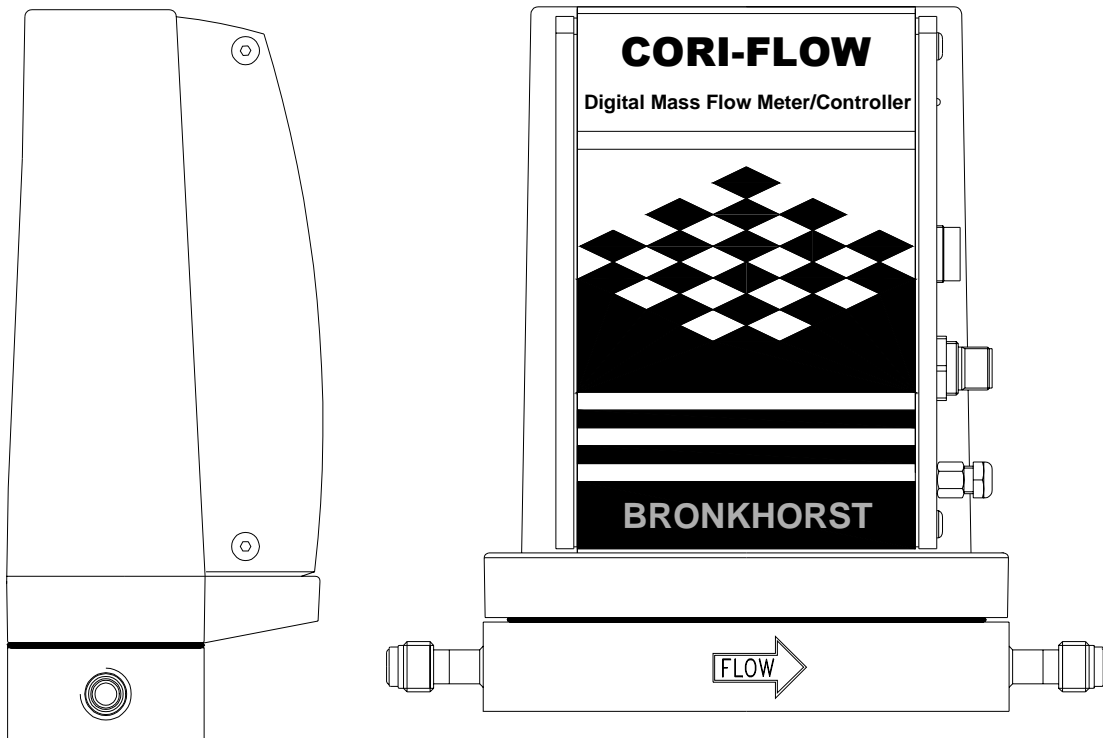

### Controller housing with C5 valve

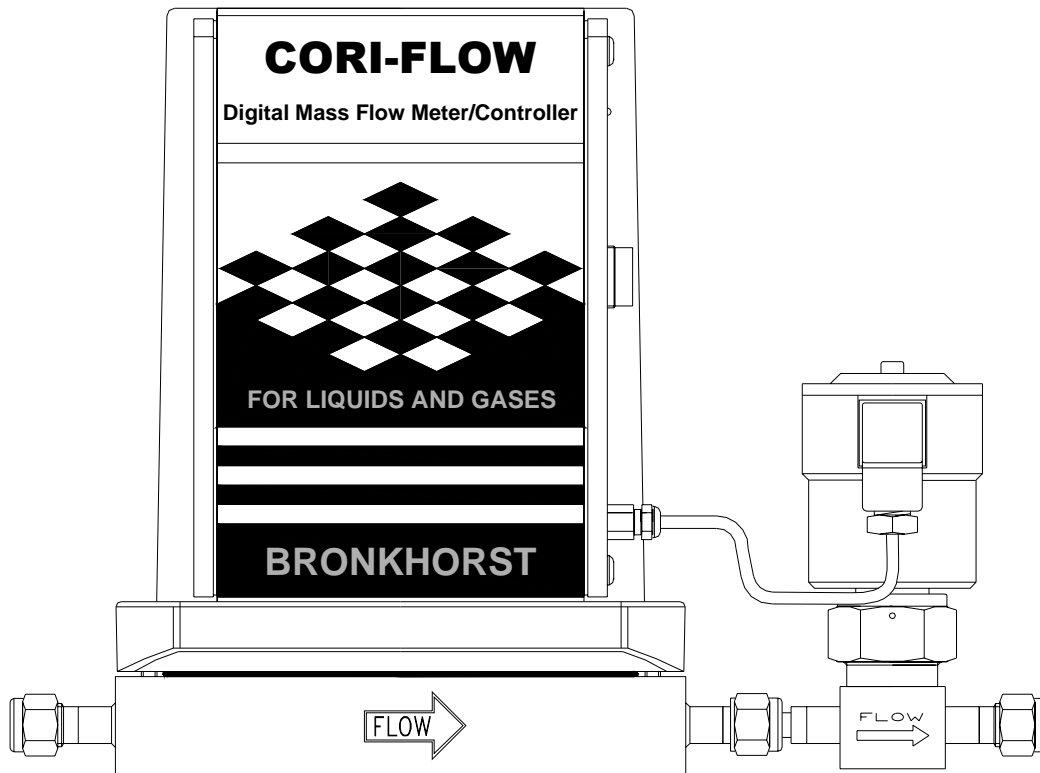

#### 1.1.3 Valves

CORI-FLOW controllers are fitted with a modular valve. The valve is attached by means of a port connector.

#### Valves for liquids

##### C2

Direct operating valve for liquids ("open" sleeve) metal sealed with purge connector.

C2 valve = normally closed

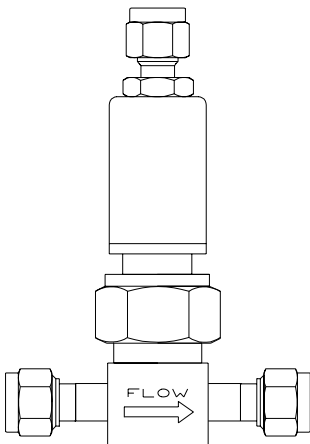

##### C4 valve

Direct operating valve for gases and liquids. (bellow)

C4 valve = Normally closed.

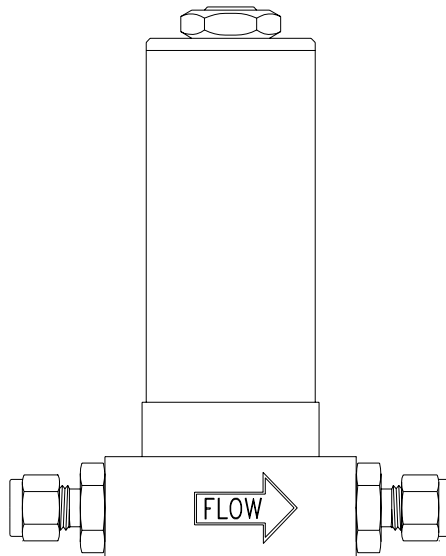

##### C5 valve

Direct operating valve for liquids ("open" sleeve) metal sealed.

C5 valve = normally closed

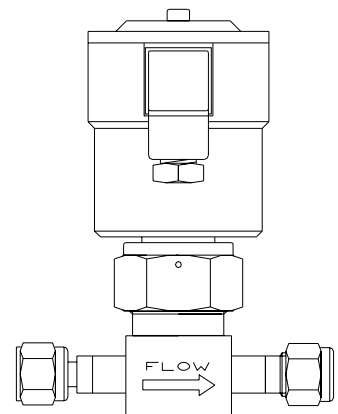

## Valves for gases

### C0 / C1 valve

Direct operating valve for gases  
metal sealed  
C0 valve = normally closed  
C1 valve = normally open

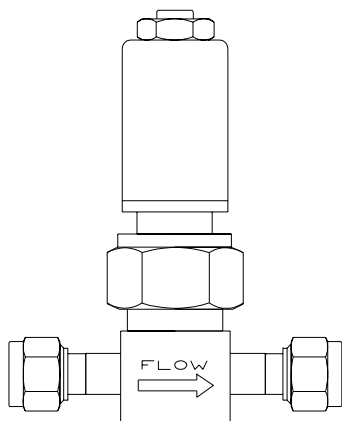

### C4 valve

Direct operating valve for gases and liquids. (bellow)  
C4 valve = Normally closed.

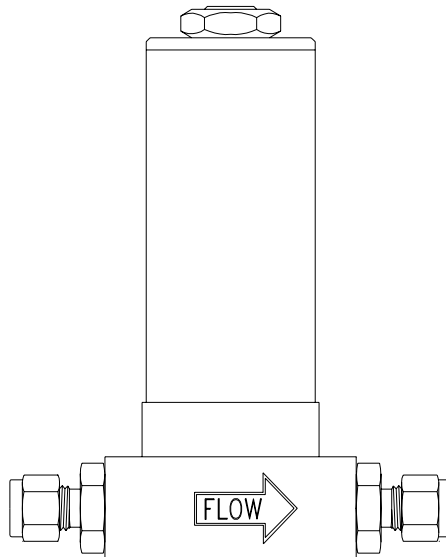

### C5 valve

Direct operating valve for gases  
metal sealed  
C5 valve = normally closed

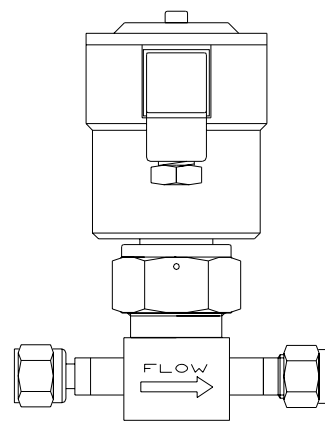

## 1.2 Sensor principles

### 1.2.1 CORI-FLOW sensor

CORI-FLOW mass flow meters/controllers operate according to the Coriolis principle.  
The instrument can be used to simultaneously measure the mass flow and temperature.

#### Measuring Principle

When a fluid flows through a vibrating tube, Coriolis forces are generated which bend or twist the tube. The extremely small tube displacements are detected by optimally positioned sensors and evaluated electronically.

Since the measured phase shift of the sensor signals is proportional to the mass flow, the CORI-FLOW measures the mass flow directly. The measurement principle is independent of the density, temperature, viscosity, pressure or conductivity. The tubes always vibrate at their natural frequency, which is a function not only of the tube geometry and the tube material properties but also the mass of the fluid in the vibrating tubes.

## 1.3 Valve principles

Control valves are not designed to provide positive shut-off, although some models have excellent capabilities for this purpose.

It is recommended to install a separate shut-off valve in the line if required. Also pressure surges, as may occur during system pressurisation must be avoided. The following models can be distinguished:

### 1.3.1 Solenoid valve

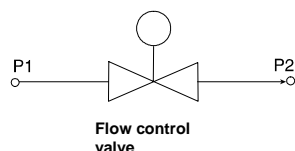

This is considered to be the standard (direct operated) control valve. In general it is a normally closed solenoid valve. The plunger is lifted by the force of the magnetic field of the coil. The orifice under the plunger is removable for optimising the orifice diameter. Also a normally opened solenoid valve is available.

### 1.3.2 Vary-P valve

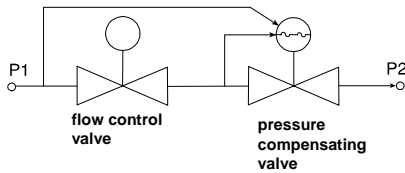

For process conditions where up- and downstream pressure varies much, a special type of valve, VARY-P has been designed. This valve consists of two valves, a solenoid operated control valve and a fixed adjusted pressure compensation valve.

### 1.3.3 Pilot operated valve

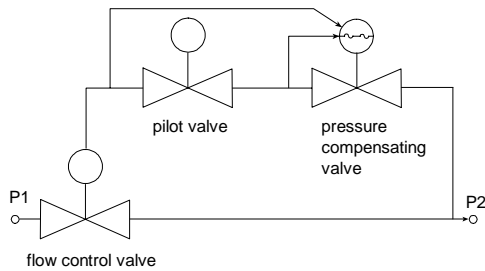

For high flow rates the pilot operated valve has been designed. A solenoid driven control valve controls the pressure difference across a piston, which lifts the main plunger.

### 1.3.4 Bellow valve

This valve type is a direct driven, low power, solenoid operated control valve. A special design, incorporating a metal bellow allows for a relatively large orifice opening to be controlled. The design is suited for low pressure or vacuum applications.

## 1.4 Software for physical properties of gases and liquids.

Bronkhorst Cori-Tech B.V. gathered the physical properties of over 600 fluids in a database called FLUIDAT. Application software, such as FLOW CALCULATIONS, enables the user to calculate properties, not only at 20°C / 1 atm but also at any temperature/pressure combination, both for gases and for liquids. Apply to your distributor for more details of this software.

## 2 INSTALLATION

### 2.1 *Receipt of equipment*

Check the outside packing box for damage incurred during shipment. Should the packing box be damaged, then the local carrier must be notified at once regarding his liability, if so required. At the same time a report should be submitted to:

BRONKHORST CORI-TECH B.V.  
RUURLO HOLLAND

If applicable, otherwise contact your distributor.

Remove the envelope containing the packing list; carefully remove the equipment from the packing box. Do not discard spare or replacement parts with the packing material and inspect the contents for damaged or missing parts.

### 2.2 *Return shipment*

When returning material, always describe the problem and if possible the work to be done, in a covering letter.

**It is absolutely required to notify the factory if toxic or dangerous fluids have been metered with the instrument!**

This to enable the factory to take sufficient precautionary measures to safe-guard the staff in their repair department. Take proper care of packaging. If possible use the original packing box. Seal instrument in plastic etc.

**Contaminated instruments must be dispatched with a completely filled in 'declaration on contamination form'.**

**Contaminated instruments without this declaration will not be accepted.**

**Note:**

If the instruments have been used with toxic or dangerous fluids the customer should pre-clean the instrument.

**Important:**

Clearly note, on top of the package, the customer clearance number of Bronkhorst Cori-Tech B.V., namely:

NL801989978B01

If applicable, otherwise contact your distributor for local arrangements.

### 2.3 *Service*

If the equipment is not properly serviced, serious personal injury and/or damage to the equipment could be the result. It is therefore important that servicing is performed by trained and qualified service personnel. Bronkhorst Cori-Tech B.V. has a trained staff of servicemen available.

## 2.4 Mounting

Install the CORI-FLOW in accordance to the direction of the FLOW arrow. The arrow for flow direction is indicated on the instrument, between process fittings.

Mount the CORI-FLOW on a firm and steady base.

Avoid in any case heavy accelerations or mechanical shocks on the instrument.

For liquids, mount the CORI-FLOW at a level in the pipe line system where gas enclosure is not possible and be certain that the CORI-FLOW is filled all the time while operating.

For gases mount the CORI-FLOW at a level in the pipe line system where condensate can not collect in the CORI-FLOW.

**Verification of leaks is required prior starting up of the process.**

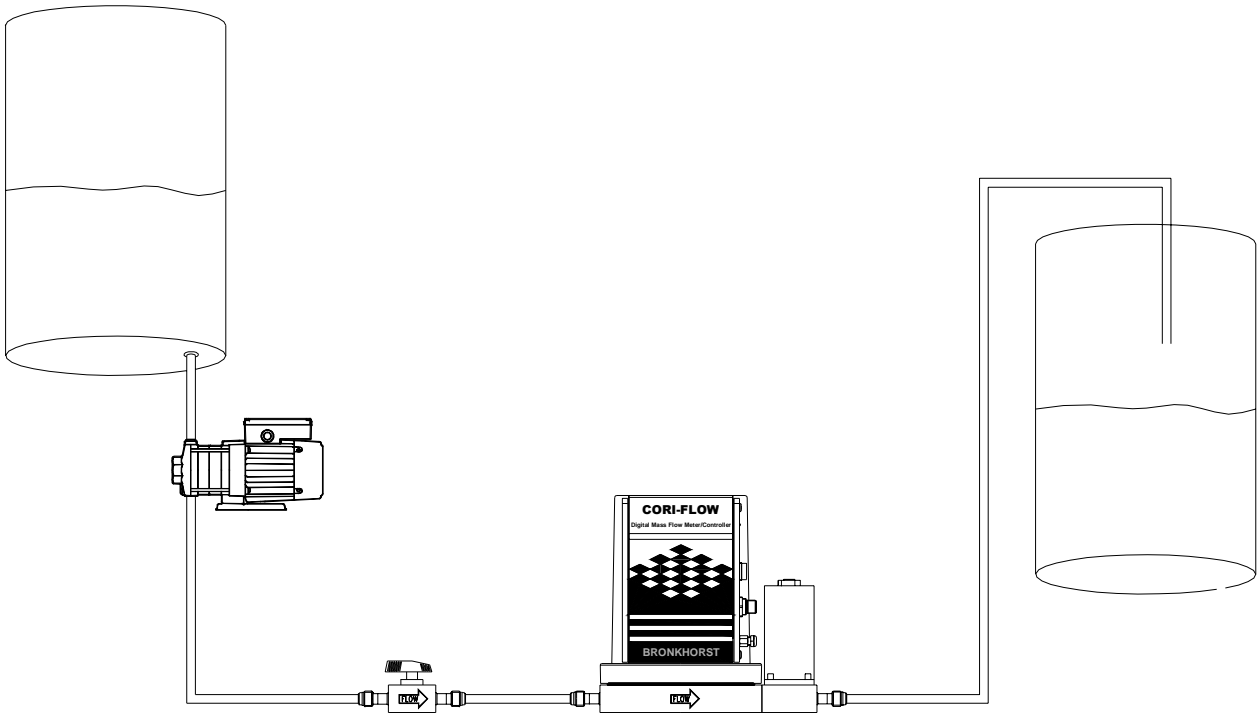

Install the sensor up side down in horizontal position for low flow (< 1000gr/h Full Scale) liquid measurement (see the following figure) and horizontal straight up for higher liquid flows and gas measurement.

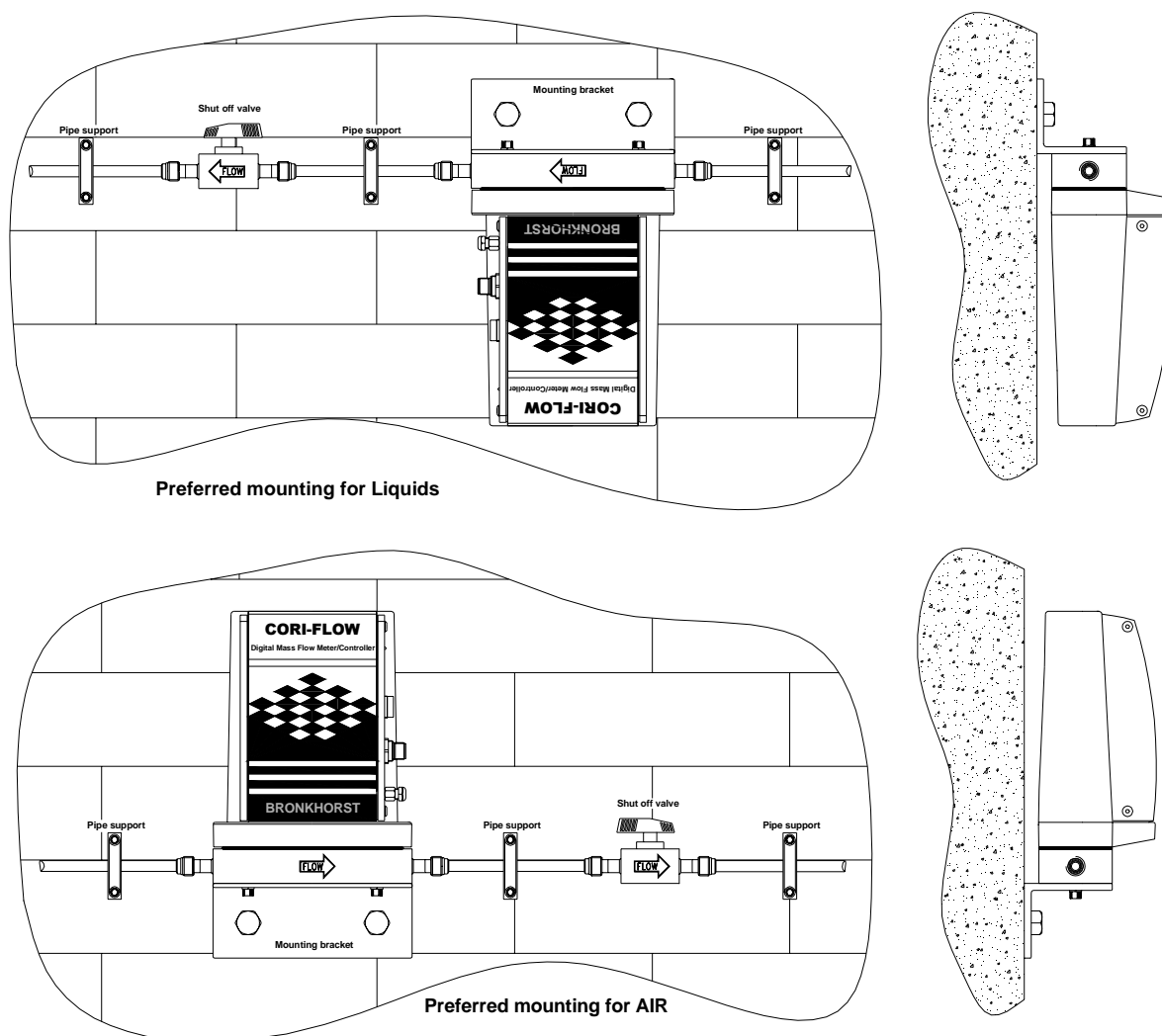

The first position, helps to remove gas bubbles out off the CORI-FLOW, the second prevents condensate collection. In order to remove gas bubbles during start-up, flushing with relatively high flow rate for some minutes is recommended.

Mount the CORI-FLOW always with screws in the body on a rigid support, the tubing has to be considered flexible, because the tube diameter is relatively low. Please avoid torsion on the piping connected to de CORI-FLOW.

For best performance please use metal installation supports for the piping or two plastic supports at each side of the CORI-FLOW. Preferably use only rigid pipes in the system. An example is shown in the pictures above.

Avoid abrupt pipeline reducers and other obstructions in the piping. They can cause cavitation or flashing inside the meter tubes.

Mount reducers outside the rigid pipe supports.

Avoid connecting the sensor directly to the process pump. The piping system must be as free of vibration as possible. Normal plant vibration has no effect on meter performance. However do not mount the sensor in areas having abnormally high vibration.

Use a high quality valve downstream from the sensor for proper zero point calibration.

**For CORI-FLOW models M52, M53, M54 two valves, upstream and downstream, are recommended.**

## **2.5 Notes for temperature changes**

The CORI-FLOW has to be installed in such a way that levels of different temperature within the CORI-FLOW are avoided. Avoid multiple heating and cooling of the instrument.

When cleaning, temperature shocks have to be avoided in any case. (max. 1°C/sec)

The temperature difference between sensor and fluid should not exceed 50°C.

After using the CORI-FLOW the first time at low temperature tighten the connector screws again in order to prevent any leakage!

Please note: if you do not tighten the screws, the leaking connector / fitting can cause damage!

After the first shrinking and tightening of the screws, no further precaution is necessary.

## 2.6 Fluid/gas connections

Bronkhorst Cori-Tech B.V. CORI-FLOW meters/controllers are equipped with compression or face-seal-fittings. For CORI-FLOW these fittings are orbitally welded to the body. For leak tight installation of compression type fittings be sure that the tube is inserted to the shoulder in the fitting body and that no dirt or dust is present on tube, ferrules or fittings. Tighten the nut finger-tight; while holding the instrument, then tighten the nut 1 turn.

If applicable follow the guidelines of the supplier of the fittings. Special types of fittings are available on request.

\* **Note:** Always check your system for leaks, before applying fluid/gas pressure. Especially if toxic, explosive or other dangerous fluids are used.

## 2.7 Piping

### BE SURE THAT PIPING IS ABSOLUTELY CLEAN!

**DO NOT** install small diameter piping on high flowrates, because the inlet jet-flow will affect the accuracy.

**DO NOT** mount abrupt angles direct on in- and outlet, especially not with high flowrates. We recommend at least 20 pipe diameters distance between the angle and the instrument.

Special care should be taken in regard to reducers placed just in front of the CORI-FLOW. High pressure drop and flow disturbance can occur which can influence the CORI-FLOW.

## 2.8 Electrical connections

Bronkhorst Cori-Tech B.V. recommends using their standard cables. These cables have the right connectors and if loose ends are used, these will be marked to prevent wrong connection.

## 2.9 Pressure testing

**Each CORI-FLOW is pressure tested to at least 1.5 times the working pressure of the process conditions stipulated by the customer, with a minimum of 8 bar.**

The tested pressure is stated on the flow meter/controller with a RED COLOURED sticker. Check test pressure before installing in the line.

If the sticker is **not** available or the test pressure is incorrect, the instrument should **not** be mounted in the process line and be returned to the factory.

Each instrument is helium leak tested to at least  $2 \cdot 10^{-9}$  mbar l/s Helium.

## 2.10 Supply pressure

Do not apply pressure until electrical connections are made. When applying pressure to the system, take care to avoid pressure shocks in the system and increase pressure gradually, especially on high pressure units incorporating a piston operated control valve.

Make sure in case of a controller that the used valve can withstand the system pressure.

## 2.11 System purging

If explosive gases are to be used, purge the process with inert dry gas like Nitrogen, Argon etc. for at least 30 minutes at a high enough flow.

In systems with corrosive or reactive fluids, purging with an inert gas is absolutely necessary, because if the tubing has been exposed to air, introducing these fluids will tend to clog up or corrode the system due to a chemical reaction with oxygen or moist air.

Complete purging is also required to remove such fluids from the system before exposing the system to air. It is preferred not to expose the system to air, when working with these corrosive fluids.

## 2.12 Seals

Bronkhorst Cori-Tech B.V. has gathered a material compatibility chart from a number of sources believed to be reliable.

However, it is a general guide only. Operating conditions may substantially change the accuracy of this guide. Therefore there is no liability for damages accruing from the use of this guide.

The customer's application will demand its own specific design or test evaluation for optimum reliability. So check if the seals like O-rings, plunger and packing gland of the capillary are correct for the process.

## 2.13 Equipment storage

The equipment should be stored in its original packing in a cupboard warehouse or similar. Care should be taken not to subject the equipment to excessive temperatures or humidity.

## 2.14 Electromagnetic compatibility

### Conditions for compliance with EMC requirements

All instruments described in this manual carry the CE-mark.

Therefore they have to comply with the EMC requirements, as they are valid for these instruments.

However compliance with the EMC requirements is not possible without the use of proper cables and connector/gland assemblies.

For good results Bronkhorst Cori-Tech B.V. can provide standard cables. Otherwise follow the guidelines as stated below.

#### 1. D-Connector assembly

Fold the shield of the cable back over the cable (the shield must be around the cable).

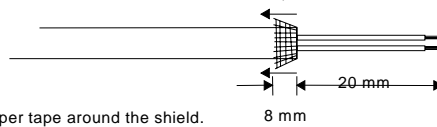

Wind a copper tape around the shield.

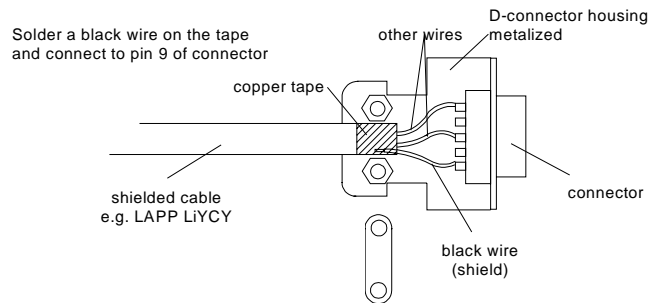

#### 2. Cable gland assembly

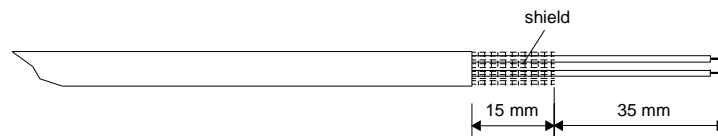

Fold the shield of the cable back over the cable (shield must be around the cable).

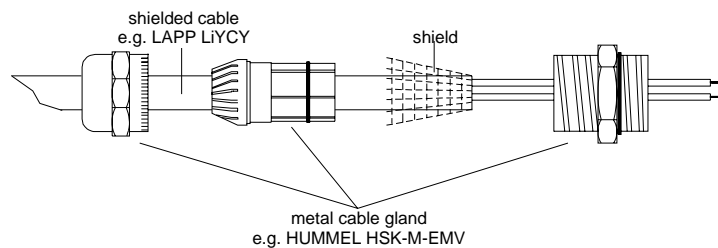

Mount the metal PG cable gland as shown in the drawing above.

### 3. Connector CORI-FLOW

#### 8 DIN CONNECTOR AMPHENOL

C091 31D008 200 2

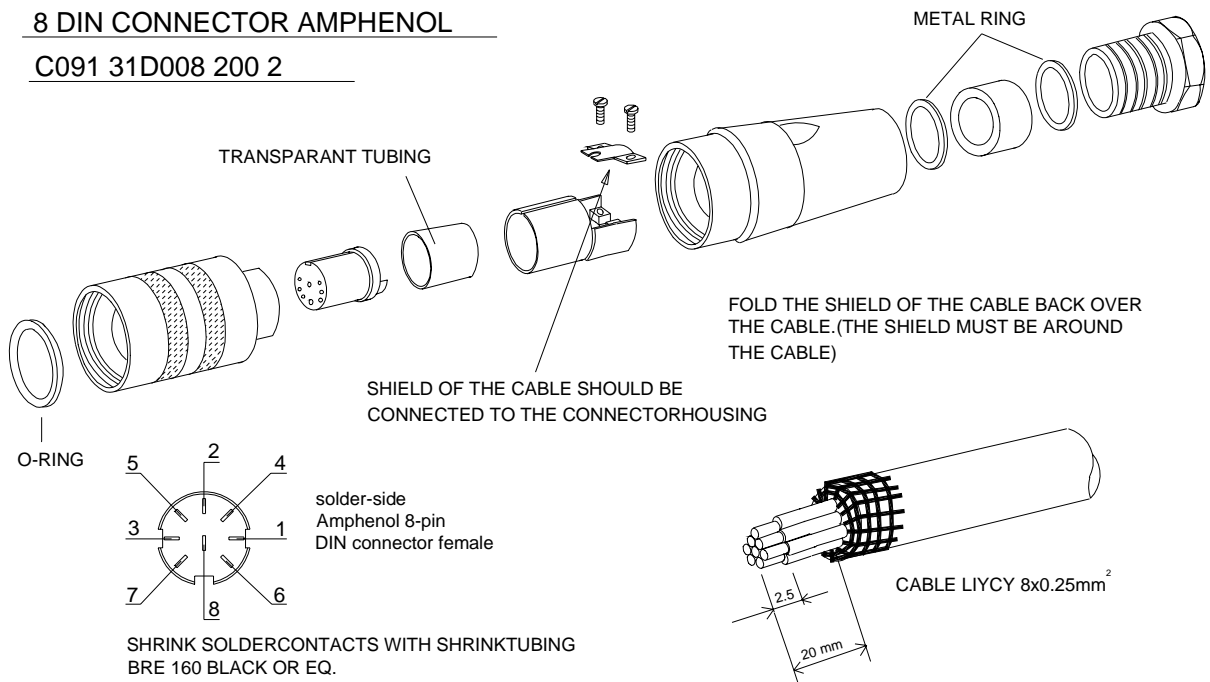

#### 8 DIN CONNECTOR BINDER

SERIE 423 99.5672.19.08

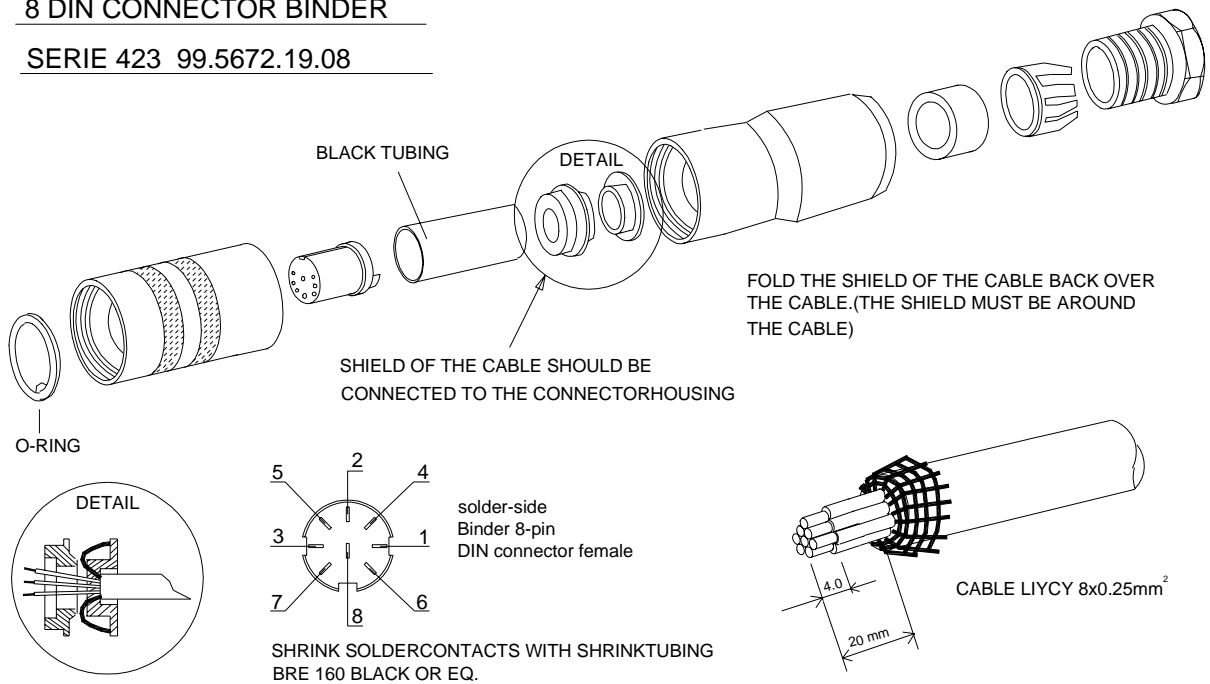

**Note:**

When connecting the system to other devices (e.g. to PLC), be sure that the integrity of the shielding is not affected. Do not use unshielded wire terminals.

1. For FLOW-BUS S(F)TP data (patch) cable connection to M12 connectors follow the instructions of the supplier. It is important to use shielded twisted pair cables and shielded RJ45 modular jack connectors.
2. For PROFIBUS-DP, Modbus or DeviceNet data cable connections follow the instructions of the cable suppliers for the specific field-bus system.

### 2.15 Electro static discharge

This instrument contains electronic components that are susceptible to damage by static electric discharges. Proper handling procedures must be taken during installation, removing and connecting the electronics.

## 3 OPERATION

### 3.1 General

The Bronkhorst Cori-Tech B.V. instruments are designed in such a way that they will meet user process requirements in the best possible way.

The CORI-FLOW meters/controllers can be powered from +15 Vdc to +24 Vdc.

When providing your own power supply be sure that voltage and current rating are according to the specifications of the instrument(s) and furthermore that the source is capable of delivering enough power to the instrument(s).

Cable wire diameters should be sufficient to carry the supply current and voltage losses must be kept as low as possible. When in doubt: consult factory.

Digital instruments can be operated by means of:

1. Analog interface (0...5Vdc/0...10Vdc/0...20mA/4...20mA)
2. RS232 interface (connected to COM-port by means of special cable on 38400 Baud)
3. FLOW-BUS
4. PROFIBUS-DP
5. DeviceNet
6. Modbus (special request)

Option 1 and 2 are always present on multibus instruments. An interface to any available fieldbus is optional. Operation via analog interface, RS232 interface and an optional fieldbus can be performed at the same time. A special parameter called "control mode" indicates to which setpoint the controller should listen: analog or digital (via fieldbus or RS232). The RS232 interface behaves like a FLOW-BUS interface.

When using more interfaces at the same time, reading can be done simultaneously without problems.

When changing a parameter value, the last value send by an interface will be valid.

Also the push-button switch and the LED's on the right side of the instrument can be used for manual operation of some options.

The green LED will indicate in what **mode** the instrument is active.

The red LED will indicate **error/warning** situations.

### 3.2 Power and warm-up

Before switching on power check if all connections have been made according to the hook-up diagram which belongs to the instrument.

It is recommended to turn on power before applying pressure on the instrument and to switch off power after removing pressure.

Check fluid connections and make sure there is no leakage. If needed purge the system with a proper fluid.

For a gas instrument only purging with gases is allowed. Liquid instruments may be purged with either a gas or a liquid, whatever is needed for the purpose.

Turn on power and allow at least 30 minutes to warm up and stabilise. In cases where no electronics are involved (valves only) warming up is not needed.

During warm-up period, fluid pressure may either be on or off.

### 3.3 Zeroing

#### 3.3.1 Zeroing with the Micro-switch





Before using the instrument zeroing is required.

- **Set process conditions**  
After warm-up, pressure up the system and fill the CORI-FLOW according to the process conditions
- **Stop flow**  
Make sure no flow is going through the instrument by closing valves near the instrument (for types M52, M53 and M54 two valves (one before and one after) the instrument are required).
- **Press and hold, Until**  
With no flow, use the push-button switch (#) on the right side of the instrument to start the zero adjustment procedure.  
Press the push-button (#) and hold it, after a short time the red LED will go ON and OFF then the green LED will go ON. At that moment release the push-button (#).
- **Zeroing**  
The zeroing procedure will start at that moment and the green LED will blink fast. The zeroing procedure waits for a stable signal and saves the zero. If the signal is not stable zeroing will take long and the nearest point to zero is accepted. The procedure will take approx. 10 sec.  
So make always sure that there is going no flow through the instrument when performing the zeroing procedure.
- **Ready**  
When indication is showing 0% signal and the green indication LED is burning continuously again, then zero has been performed well.

**ATTENTION**

**Zero instrument before use**

**PROCEDURE**

- Set process conditions
- Stop flow 
- Press and hold 
- Until 
- Zeroing 
- Ready 

#### 3.3.2 Zeroing through the digital communication

It is also possible to start the automatic zero adjustment procedure through the FLOW-BUS, using a E-7000 readout/control unit or a software program on a PC, connected to a FLOW-BUS interface module.

The following parameters must be used for zeroing an instrument:

```

Initreset[unsigned char, RW,0...255, DDEpar. = 7, Proces/par. = 0/10]
Cntrlmode      [unsigned char, RW,0...255, DDEpar. = 12, Proces/par. = 1/4]
CalMode       [unsigned char, RW,0...255, DDEpar. = 58, Proces/par. = 115/1]
  
```

- **Set process conditions**  
Warm-up, pressure up the system and fill the instrument according to the process conditions.
- **Stop flow**  
Make sure no flow is going through the instrument by closing valves near the instrument.
- **Send parameters**  
Send the following values to the parameters in this sequence.
 

```

Initreset64
Cntrlmode      9
Calmode       255
Calmode       0
Calmode       9
      
```
- **Zeroing**  
The zeroing procedure will start at that moment and the green LED will blink fast. The zeroing procedure waits for a stable signal and saves the zero. If the signal is not stable zeroing will take long and the nearest point to zero is accepted. The procedure will take approx. 10 sec.  
So make always sure that there is going no flow through the instrument when performing the zeroing procedure.
- **Ready**  
When indication is showing 0% signal and the green indication LED is burning continuously again, then zero has been performed well. Also parameter Cntrlmode goes back to zero.  
As last send 0 to parameter Initreset.

### 3.4 Start-up

Turn on fluid supply gently. Avoid pressure shocks, and bring the instrument gradually up to the level of the actual operating conditions. Also switch off fluid supply gently.

### 3.5 Operating conditions

Each instrument has been calibrated and adjusted for customer process conditions. Controllers or valves may not operate correctly, if process conditions vary too much, because of the restriction of the orifice in the valve.

### 3.6 Instrument performance

#### 3.6.1 Meters

Each meter has a step-response of about 50ms. The special adaptive filtering technique in the CORI-FLOW detects that the flow is changing rapidly and will decrease filtering immediately so a fast response is possible. After the flow change the filter will increase to get a steady signal.

#### 3.6.2 Controllers

The dynamic response of a controller is factory set. Standard settling-time is defined as the time to reach the setpoint (and stay) within  $\pm 2\%$  of the initial setpoint. The settling time depends on the properties of the flow, the system pressure and the valve type used. It can vary between 500ms and 3 seconds.

The control mode is factory set in such a way that after a stepwise change in the flow, there will be little overshoot.

### 3.7 Manual operation

By means of manual operation of the push-button switch (#) some important actions for the instrument can be selected/started. These options are available in both analog and BUS/digital operation modes. (See also manual operation in document number 9.17.023)

These functions are:

- Reset (instrument firmware-program reset)
  - Zeroing
  - Restore factory settings (in case of unintentionally change of the settings)
- for FLOW-BUS only:
- Automatic installation to FLOW-BUS (installs instrument to free address)
  - Remote installation to FLOW-BUS (instruments will be installed by E-7000 or PC-software)

### 3.8 Analog operation

**Digital** instruments can be operated with analog signals through the 8-pin circular connector. The instruments are compatible in use with **analog** instruments on this point.

Analog operated instruments, can be hooked up using an 8-wire shielded cable, connected according to the Bronkhorst Cori-Tech standard.

Each electronic P. C. board is set for one of the following output (and corresponding input) signals:

Signal code	output (sensor) signal	input (setpoint) signal
A	0...5 Vdc	0...5 Vdc
B	0...10 Vdc	0...10 Vdc
F	0...20 mA (sourcing)	0...20 mA (sinking)
G	4...20 mA (sourcing)	4...20 mA (sinking)

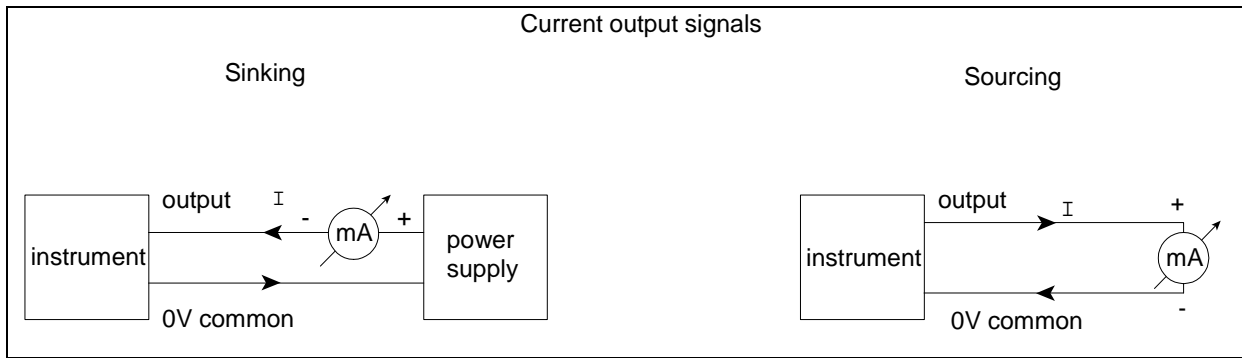

For meters only the output signal is available.

At analog operation the following parameters are available:

- measured value
- setpoint (controllers only)
- valve voltage (controllers only)

**Note:**

When operating the instrument through the analog interface it is possible to connect the instrument to any supported fieldbus system (or RS232-interface with special cable) for reading/changing parameters (e.g. controller response or other fluid selection).

For FLOW-BUS versions of the instruments a readout/control module for digital instruments can be temporarily connected to the M12 Connector.

### 3.9 *BUS / digital operation*

Operation via fieldbus reduces the amount of cables to build a system of several instruments and offers more parameter values to be monitored/changed by the user.

See instruction manual: operating digital mass flow / pressure instruments for more details (document nr. 9.17.023).

Operation by means of a fieldbus adds a lot of extra features (compared to analog operation) to the instruments.

Such as:

- setpoint slope (ramp function on setpoint for smooth control)
- 8 selectable fluids
- direct reading at readout/control module or host computer
- testing and self diagnosis
- response alarm (setpoint-measure too high for too long time)
- several control/setpoint modes (e.g. purge/close valve)
- master/slave modes for ratio control (FLOW-BUS only)
- identification (serialnumber, modelnumber, device type, user tag)
- adjustable minimal and maximal alarm limits
- (batch) counter
- adjustable response time for controller when opening from zero
- adjustable response time for normal control
- adjustable response time for stable control ( $|\text{setpoint-measure}| < 2\%$ )

Special software like FlowDDE, FlowPlot and FlowView can be used to control these settings.

For operation of digital instruments by means of a specific fieldbus system or RS232, see following documents (available as PDF-file):

- for FLOW-BUS document number: 9.17.024
- for PROFIBUS-DP document number: 9.17.025
- for DeviceNet document number: 9.17.026
- for RS232 document number 9.17.027
- for Modbus document number 9.17.035

Note:

Special RS232 cable has partnr. 7.03.348 and consists of a T-part with 1 male and 1 female 8DIN connector on one instrument-side and a normal female sub-D 9 connector on the side of the computer.

By means of this cable it is possible to offer RS232 communication and still be able to connect power-supply and analog interface through the (analog) 8DIN connector.

RS232 communication is only possible with a baudrate of 38.4 KBaud and can be used for either:

- Uploading new firmware by means of a special program (for trained BHT-service personnel only)
- Servicing your instrument using BHT-service programs (for trained BHT-service personnel only)
- Operating your instrument using FLOWDDE, FLOWB32.DLL or RS232-ASCII protocol (end user)

## 4 MAINTENANCE

### 4.1 General

No routine maintenance is required to be performed on the meters or controllers. In case of severe contamination it may be required to clean the valve orifice separately.

### 4.2 CORI-FLOW sensor

The CORI-FLOW sensor is constructed in such a way that there is little dead volume. The sensor is maintenance free.

### 4.3 Controllers

All sensor types can be combined with a control valve to be operated together as a control loop. Controller systems are either available as separate units; a sensor and a control valve, or as an integrated unit. If applicable maintenance procedures are described under "control valves"

### 4.4 Control valves

Control valves cannot be used for shut-off and/or on-off applications. Pressure surges, as may occur during system pressurisation or deflation must be avoided.

#### 4.4.1 Solenoid valves

These are considered to be the directly operated control and pilot valves. They can be disassembled in the field by the user for cleaning and servicing. The parts can be cleaned with a cleaning liquid, or in an ultrasonic bath.

To disassemble the valve proceed as follows:

- a) disconnect the instrument connector (not necessary with separate valve)
- b) remove the hex nut on top of the valve assembly
- c) lift the cover (coil) assembly
- d) unscrew the flange
- e) lift valve assembly carefully from the base
- f) unscrew set screw for the orifice and subsequently loosen the orifice and the orifice holder
- g) remove the plunger assembly

Clean parts and carefully re-assemble in reverse order. It is recommended to replace the O-rings prior to re-assembly.

After having re-assembled the control valve, it is recommended to check the control characteristics of the valve. This can best be done by using a separate variable 15 Vdc power supply source.

Proceed as follows:

- disconnect the valve leads and connect to supply source
- apply gas pressure as per working conditions
- apply power by gradually increasing voltage
- the valve should open at  $7 \text{ Vdc} \pm 3 \text{ Vdc}$
- the fully opened position is reached at approx.  $9 \text{ Vdc} \pm 1.5 \text{ Vdc}$ .

In case the valve does not operate within the voltage levels stated, then it must be disassembled, and the orifice must be adjusted to the proper position.

Re-assemble valve and repeat procedure if required.

#### 4.4.2 Vary-P valve

The vary-P valve is designed to cope with extremely varying process conditions on either upstream or downstream side of the valve or a combination of these.  $\Delta p$  can vary over a wide range. The basic control valve is a direct operated solenoid control valve.

The design has been patented.

For orifice selection and maintenance other than the pilot valve consult the factory.

### 4.4.3 Pilot operated valve

This control valve is an indirect control valve, consisting of a spring loaded membrane/orifice system which is positioned by a solenoid operated direct control (pilot valve). The two devices are integrated in one block. Basically follow the same procedures for dis-assembly as stipulated under "Solenoid valves"  
For cleaning purposes it may be required to dis-assemble further, i.e. also remove the membrane assembly.

For pilot operated valves the maximum pressure drop is limited to 20 bar. If the pressure drop during start-up is higher, it is preferred to install a bypass valve. During start-up this valve should be opened. Also the minimum pressure drop is limited. For exact figures consult factory or proceed according to the technical data and/or additional instructions given by the sales office or department.

**Note:**

When pressure testing a system incorporating a pilot operated control valve, a special procedure must be followed in order to prevent damage to the valve. In such cases it is necessary to contact the factory prior to do this.

### 4.4.4 Bellows valve

These valves are suited for low pressure or vacuum applications. The user should not disassemble this model.

## 4.5 $K_v$ -value calculation

This calculation method can be used to determine the  $K_v$ -value of the main orifice of a control valve.

### 4.5.1 For gases

Determine desired  $\Delta p$  across valve.

$\Delta p$  must be at least 20% of supply pressure, or in closed loop systems, of total pressure difference in the loop.

If  $\Delta p$  is 20-50% of supply pressure, use formula:

$$K_v = \frac{\Phi_m}{514 \cdot \rho_n \sqrt{\Delta p \cdot p_2}} \sqrt{\rho_n \cdot T} \quad \text{undercritical}$$

If  $\Delta P$  is 50-100% of supply pressure, use formula:

$$K_v = \frac{\Phi_m}{257 \cdot \rho_n \cdot p_1} \sqrt{\rho_n \cdot T} \quad \text{overcritical}$$

Units:

$\Phi_m$  = flow [kg/h]

$p_1$  = supply pressure [bara]

$p_2$  = downstream pressure [bara]

$\Delta p$  = pressure difference ( $p_1 - p_2$ ) [bara]

$T$  = temperature [K]

$\rho_n$  = density [ $\text{kg}/\text{m}^3$ ]

The orifice diameter can be determined by:  $d = 7.6 \sqrt{K_v}$  [mm]

### 4.5.2 For Liquids

Determine desired  $\Delta p$  across valve.

$\Delta p$  must be at least 50% of supply pressure

**Kv-value calculation**

$$K_v = \frac{\Phi_m}{\rho} \sqrt{\frac{\rho}{\Delta p \cdot 1000}}$$

Units:            flow                    -  $\Phi_m$  (kg/h)  
                   density                    -  $\rho$  (kg / m<sup>3</sup>) at 20° C and 1 atm.  
                   delta p                    -  $\Delta p$  (bard)

The orifice bore diameter can be determined by:

$$d = 7.6 \sqrt{K_v} \quad [\text{mm}]$$

For C2 type of valves the diameter of the orifice can be calculated as shown above or looked up in the graph below.

$$\Phi_{vH_2O} = \Phi_{v\text{customer}} \sqrt{\frac{\rho_{\text{customer}}}{\rho_{H_2O}}}$$

in which:         $\Phi_v$         = volume flow  
                    $\rho$             = density

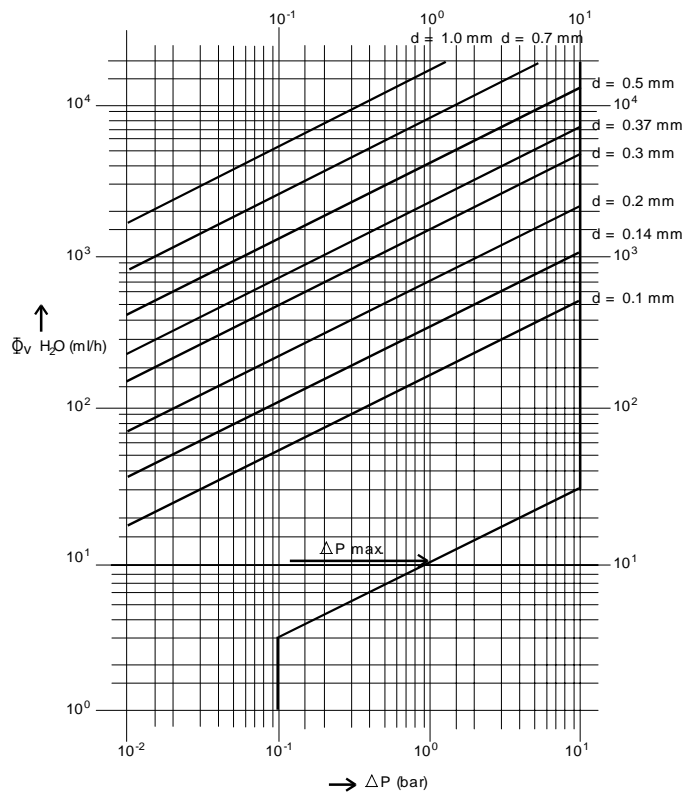

If liquids have viscosity's >15 cs (water = 1 cs), the flat orifice and plunger type control mechanism cannot be used. For measuring systems only check maximum possible viscosity with factory.

### 4.6 Calibration procedure

All instruments are factory calibrated. For re-calibration or re-ranging contact supplier or factory.

## **5 DIGITAL INSTRUMENT**

See document number 9.17.023 for detailed description.

This document is available as PDF on the Multibus documentation/software tool CD.

## **6 INTERFACE DESCRIPTION**

For a description of the available interfaces see document numbers:

9.17.024 for FLOW-BUS  
9.17.025 for PROFIBUS-DP  
9.17.026 for DeviceNet  
9.17.027 for RS232  
9.17.035 for Modbus (special request)

These documents are available as PDF on the Multibus documentation/software tool CD.

## 7 TROUBLESHOOTING

### 7.1 General

For a correct analysis of the proper operation of a CORI-FLOW meter or controller it is recommended to remove the unit from the process line and check it without applying fluid supply pressure. In case the unit is dirty, this can be ascertained immediately by loosening the compression type couplings and, if applicable the flange on the inlet side.

Furthermore remove the two covers and check if all connectors are fixed properly. Energising or de-energising of the instrument indicates whether there is an electronic failure. When powering up the red LED is on and the green LED is flashing for a second or two. Then the instrument should go in normal operation mode. See document number 9.17.023 for detailed description of the LED indication.

After that, fluid pressure is to be applied in order to check behaviour.

### 7.2 Troubleshooting summary general

Symptom	Possible cause	Action
No output signal	No power supply	1a) check power supply 1b) check cable connection
	Output stage blown-up due to long lasting shortage and/or high-voltage peaks	1c) return to factory
	Supply pressure too low, or differential pressure across meter too low	1d) increase supply pressure
	Valve blocked/contaminated	1e) connect 0 .. 15 Vdc to valve and slowly increase voltage while supply pressure is 'on'. The valve should open at $7V \pm 3V$ ; if not open, then clean parts and adjust valve (qualified personnel only)
	Screen in inlet fitting blocked	1f) clean screen
	Sensor failure	1g) return to factory
Maximum output signal	Output stage blown-up	2a) return to factory
	Sensor failure	2b) return to factory
Output signal much lower than setpoint signal or desired flow	Screen blocked/contaminated	3a) clean screen
	sensor blocked/contaminated	3b) clean sensor with a gas or fluid
	Valve blocked/contaminated	3c) clean valve
	Valve internal damage (swollen seat in plunger)	3d) replace plunger assembly and adjust valve or return
	Incorrect type of gas is used and/or pressure/diff. pressure is to low	3e) try instrument on conditions for which it was designed
Flow is gradually decreasing	Condensation, occurs with $NH_3$ , hydrocarbons such as $C_3H_8$ , $C_4H_{10}$ etc.	4a) decrease supply pressure and/or heat gas to be measured
	Valve adjustment has changed	4b) see '1e'
Oscillation	Supply pressure/diff. pressure too high	5a) lower pressure
	Pipeline too short between pressure regulator and Cori-Flow	5b) increase length or diameter of piping upstream
	External vibration is present	5c) Remove external vibration
	Valve sleeve or internals damaged	5d) replace damaged parts and adjust valve, see '1e' or return to factory
	Controller adjustment wrong	5e) adjust controller Software like FLOWPLOT can be used to do this. Please contact the distributor for details.
Small flow at zero setpoint	Valve leaks due to damaged plunger or dirt in orifice	6a) clean orifice and/or, when replacing plunger assembly, see '1e'
	Pressure too high or much too low	6b) apply correct pressure
	Zero procedure not done	6c) Zero the instrument
High flow at zero setpoint	Damaged diaphragm (only applicable to valves with membrane)	7a) replace membrane seal
	Zero procedure not done	7b) Zero the instrument
Disturbances in the flow	Gas in the system	8a) Purge the system
	Expansion of liquids to gasses	8b) Check properties fluid used
Calibration error	Zero procedure not done	9a) Zero the instrument
	Gas in the system	9b) Purge the system
	Measure time to short	9c) Measure long enough to get a reliable measurement
	Right reference instrument	9d) The Cori-Flow is a mass-flow meter/controller and should not be checked with a volume-meter.

Note: For other (more specific) problems see also troubleshooting parts in other documents.

## 8 SPECIAL APPLICATIONS

The CORI-FLOW can be used with special external valves like a Badger Meter valve and pumps with an analog input (4-20mA or 0-10V) and still be an integrated controller.

The CORI-FLOW can also be used as a batch controller for filling purposes.

**Please contact the sales department for these special features.**